



HLS-1000, STATIONARY MAST LIFT

MAY 2020
SHEET 1 OF 5

VERSATILE MACHINE
CAN BE OUTFITTED WITH VARIOUS ATTACHMENTS TO PERFORM A VARIETY OF LIFTING TASKS.

SPECIFICATIONS:

- CAPACITY - 1000 LBS.
- 120 VAC, 20 AMP POWER
- FOOT CONTROLS FOR LIFT/LOWER
- CUSTOM CONTROLS FOR ADDITIONAL FUNCTIONALITY

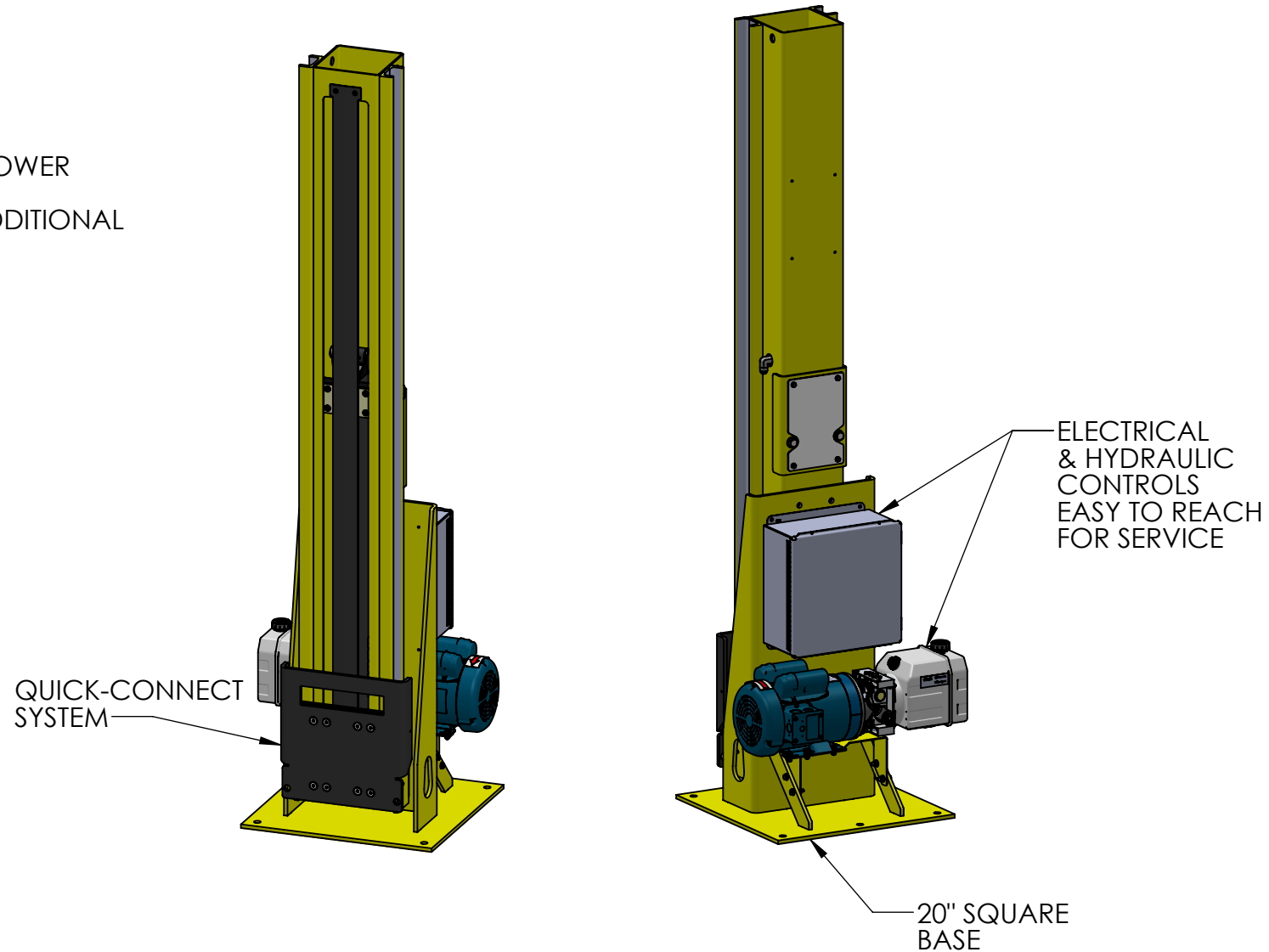



HLS-1000, STATIONARY MAST LIFT

MAY 2020
SHEET 2 OF 5

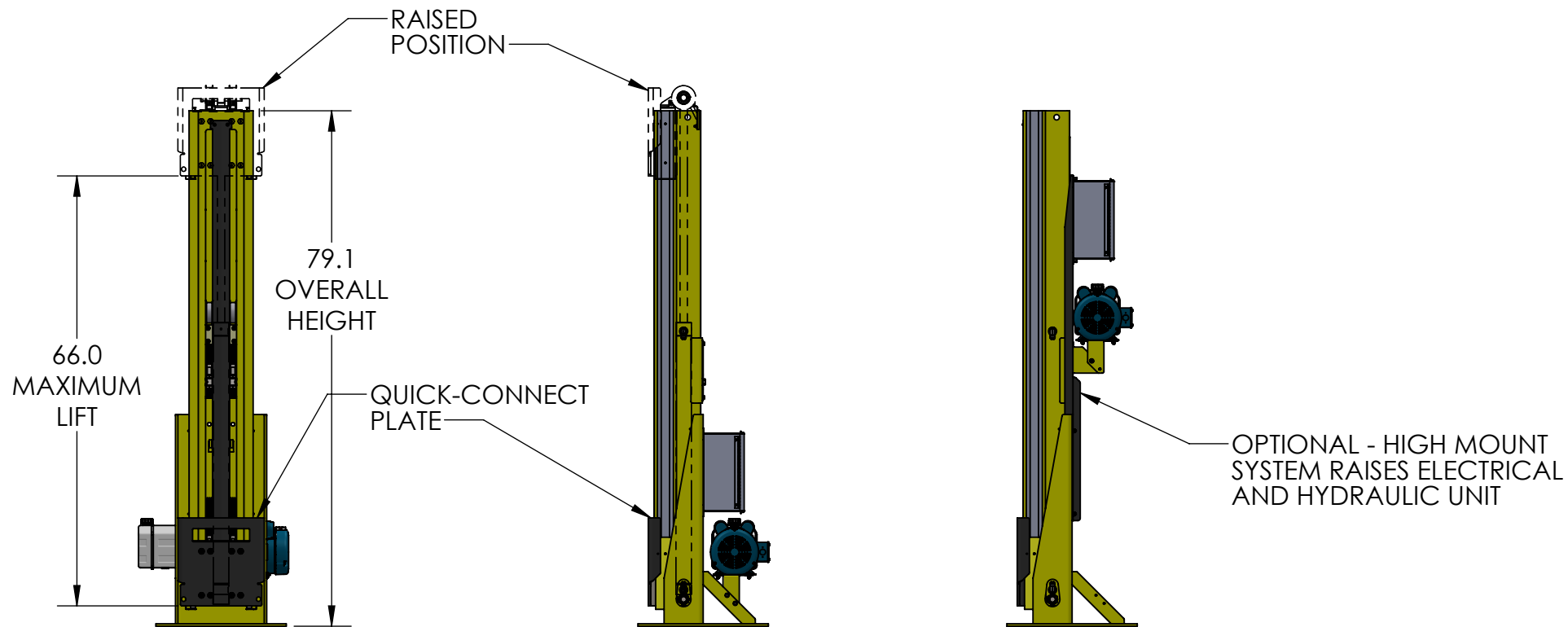
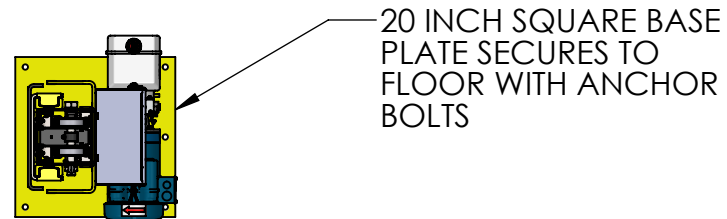



HLS-1000, STATIONARY MAST LIFT

MAY 2020
SHEET 3 OF 5

OPTIONAL - POWER ROTATOR
ALLOWS COMPLETE ROTATION
OF ATTACHMENTS FROM THE
UNIT CONTROLS

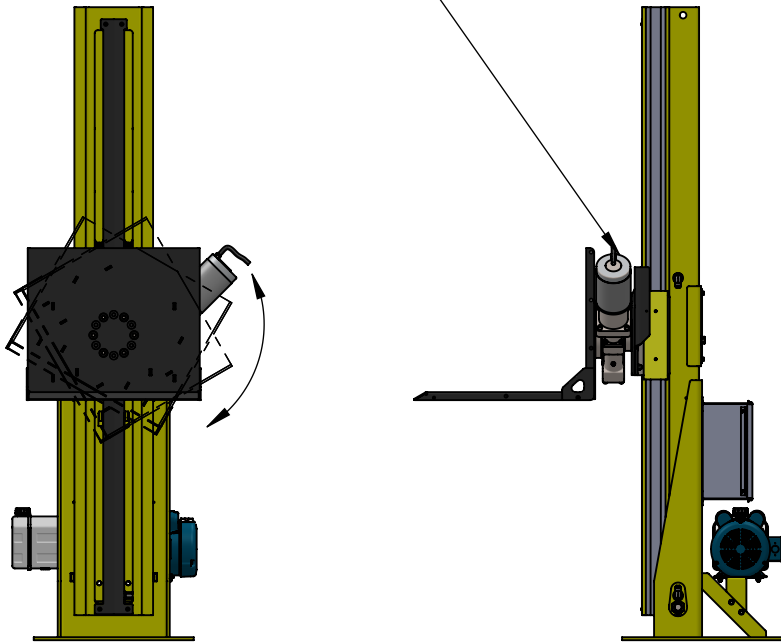

STANDARD PLATFORM
WITH POWER ROTATOR

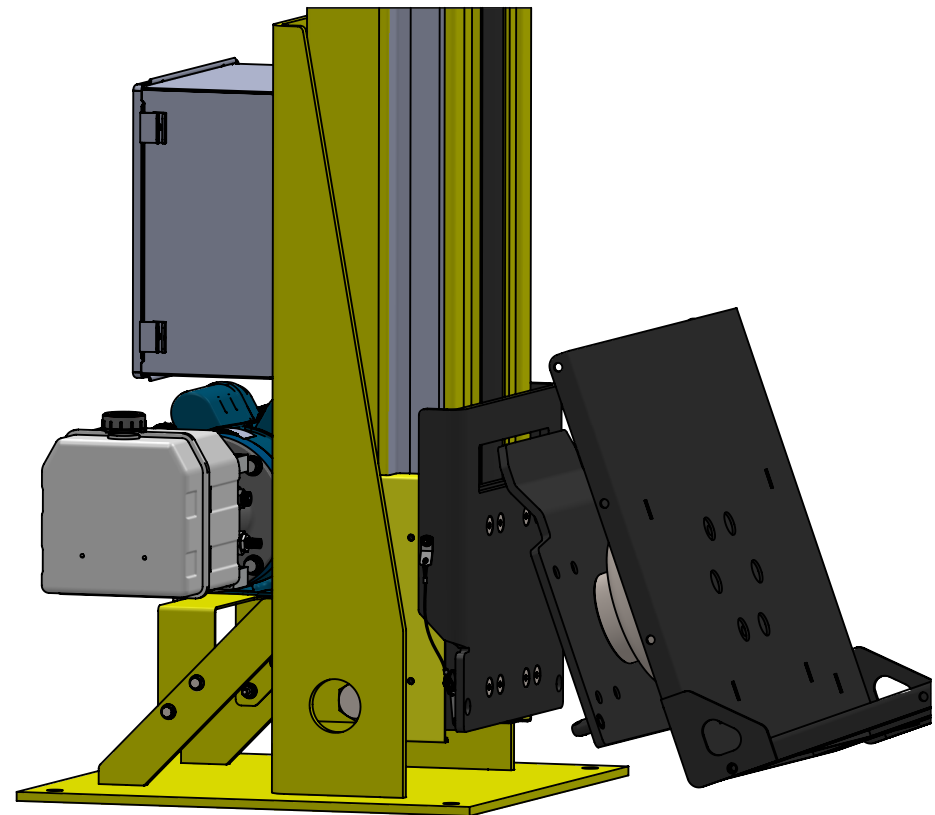

QUICK-CONNECT SYSTEM ALLOWS
TOOL-FREE CHANGE OF ATTACHMENTS



HLS-1000, STATIONARY MAST LIFT

MAY 2020
SHEET 4 OF 5

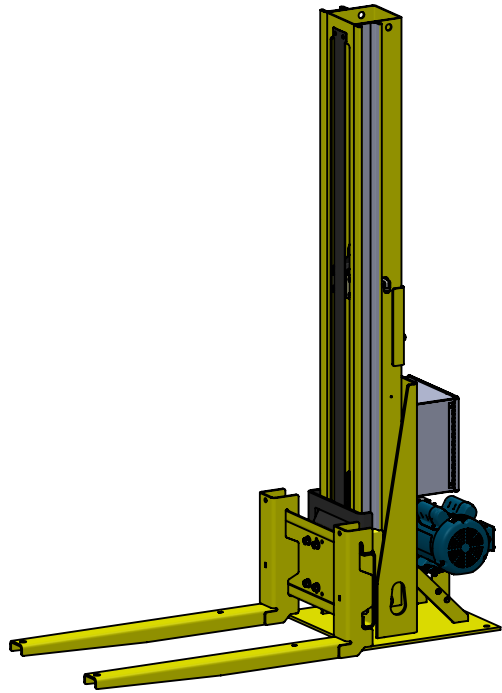

FORKS
CAN LIFT STANDARD PALLETS

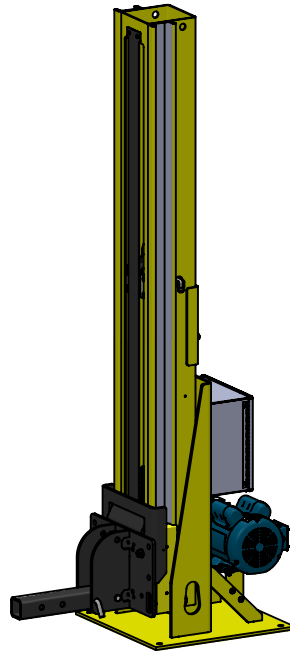

2" SQUARE RECEIVER

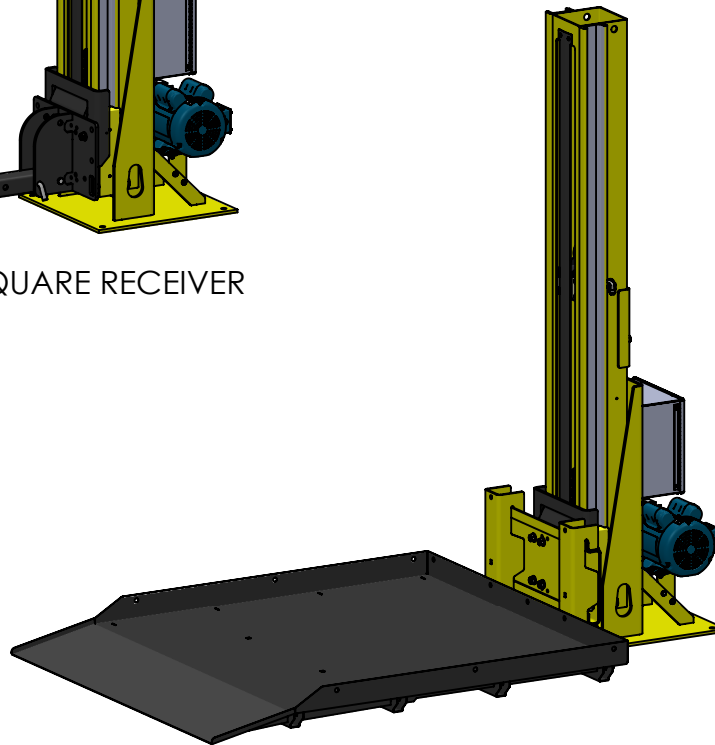

PALLET TRAY

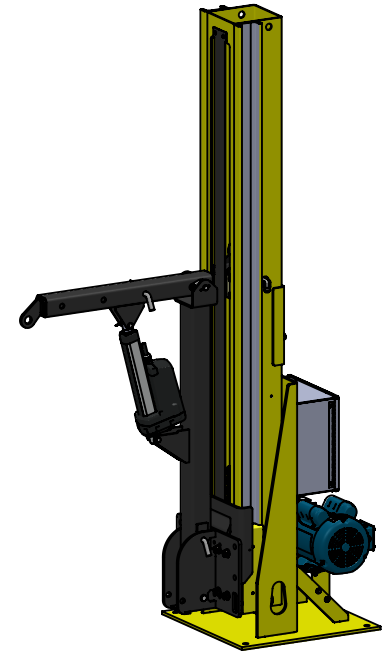

JIB ARM
WITH POWERED
ARM PIVOT



HLS-1000, STATIONARY MAST LIFT

MAY 2020
SHEET 5 OF 5

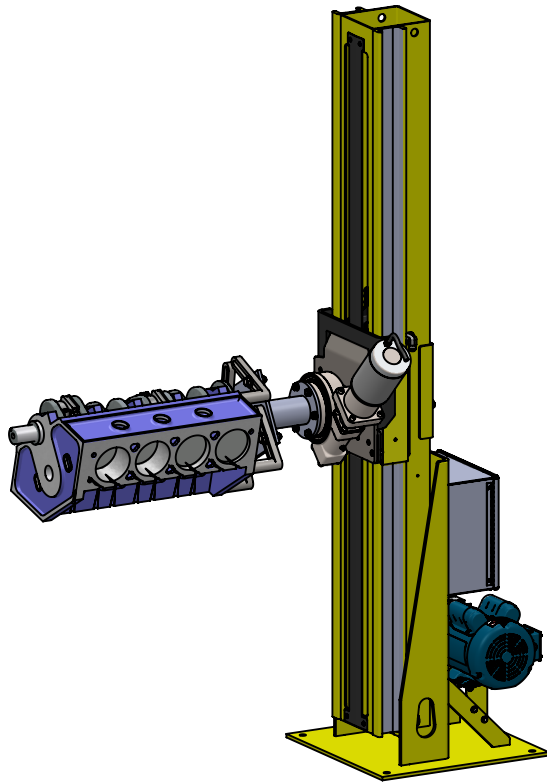

ENGINE REBUILD STATION WITH
POWERED ROTATOR

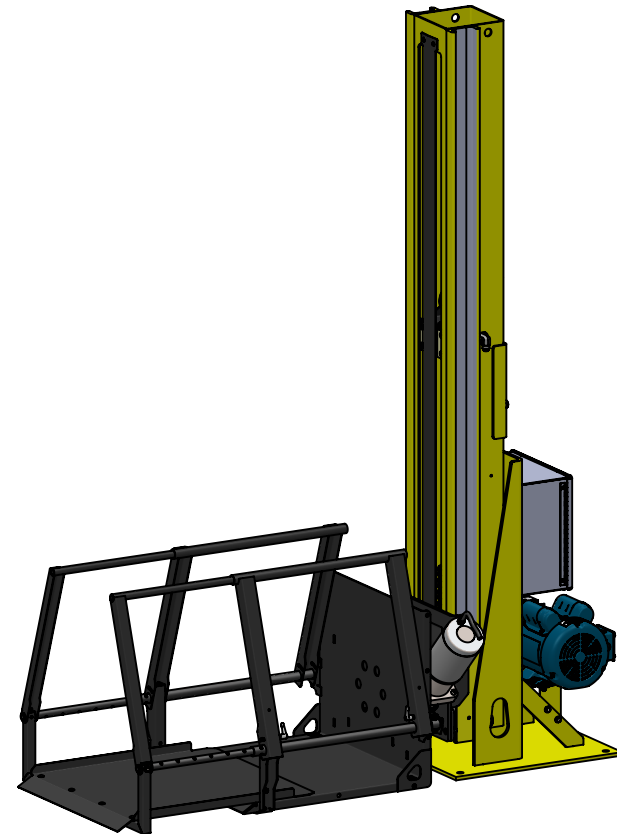

EXTENSION AND RAILS INSTALLED
ON STANDARD PLATFORM